

Installation Guide / Manual (AVA-200+)

Important Notes:

All products are thoroughly inspected and fully tested operational in factory.
 We accept no liability whatsoever for any losses due to improper operation, or any unauthorized alternation.
 All trademarks contained in this installation guide are the property of their respective owners.

AVA-200+

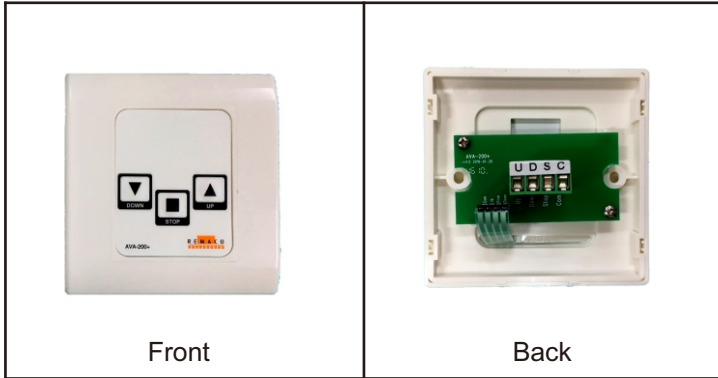

Application:

Remaco AVA-200+ designed with similar look of ESC to provide contact closure (Up/Stop/Down) for MPC-851, ESC+ and ESC-ip as options below

Description	AVA-200+
Input Voltage	0 volt (no voltage required)
Contact / Switching	Momentary Contact Closure
Control / Operation	Press Up or Stop or Down
Legend	U=Up, D=Down, S=Stop, C=Common

⚠ If connected to any voltage above 3Volt will damage the product

OPTION-1 AVA-200+ compatible with MPC-851



MPC-851

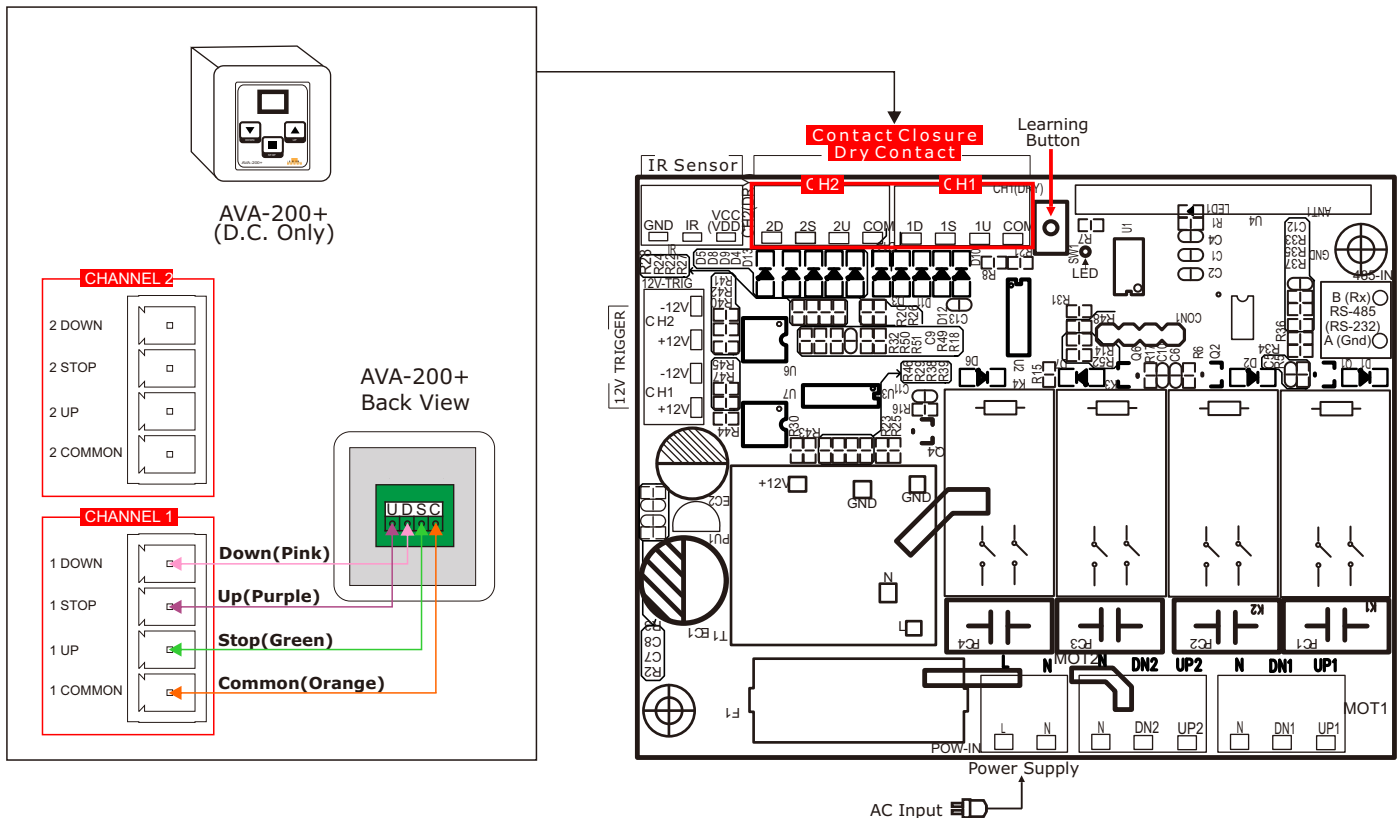

OPTION-2

AVA-200+ compatible with ESC+

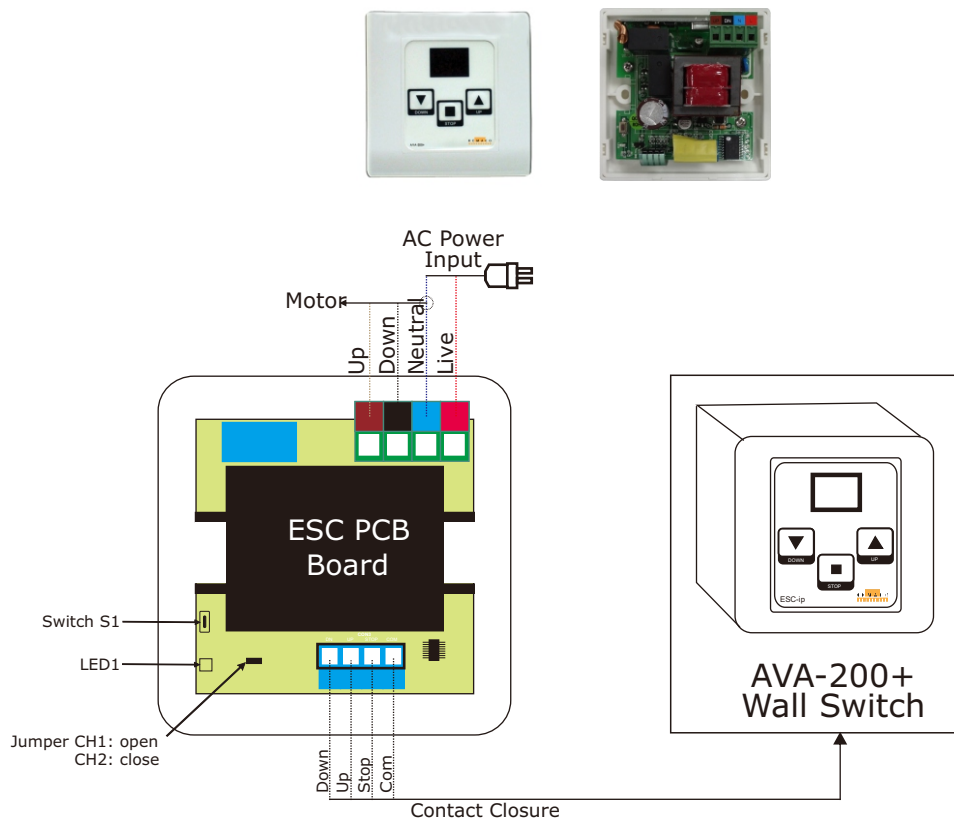

OPTION-3

AVA-200+ compatible with ESC-ip

