

# Installation Guide / Manual (ECO-1515 to ECO-2418)

## Warning

Caution with main supply and live wires. Install with qualified technician or trained personnel.

Universal Bracket can be used for any type of installation as shown below.

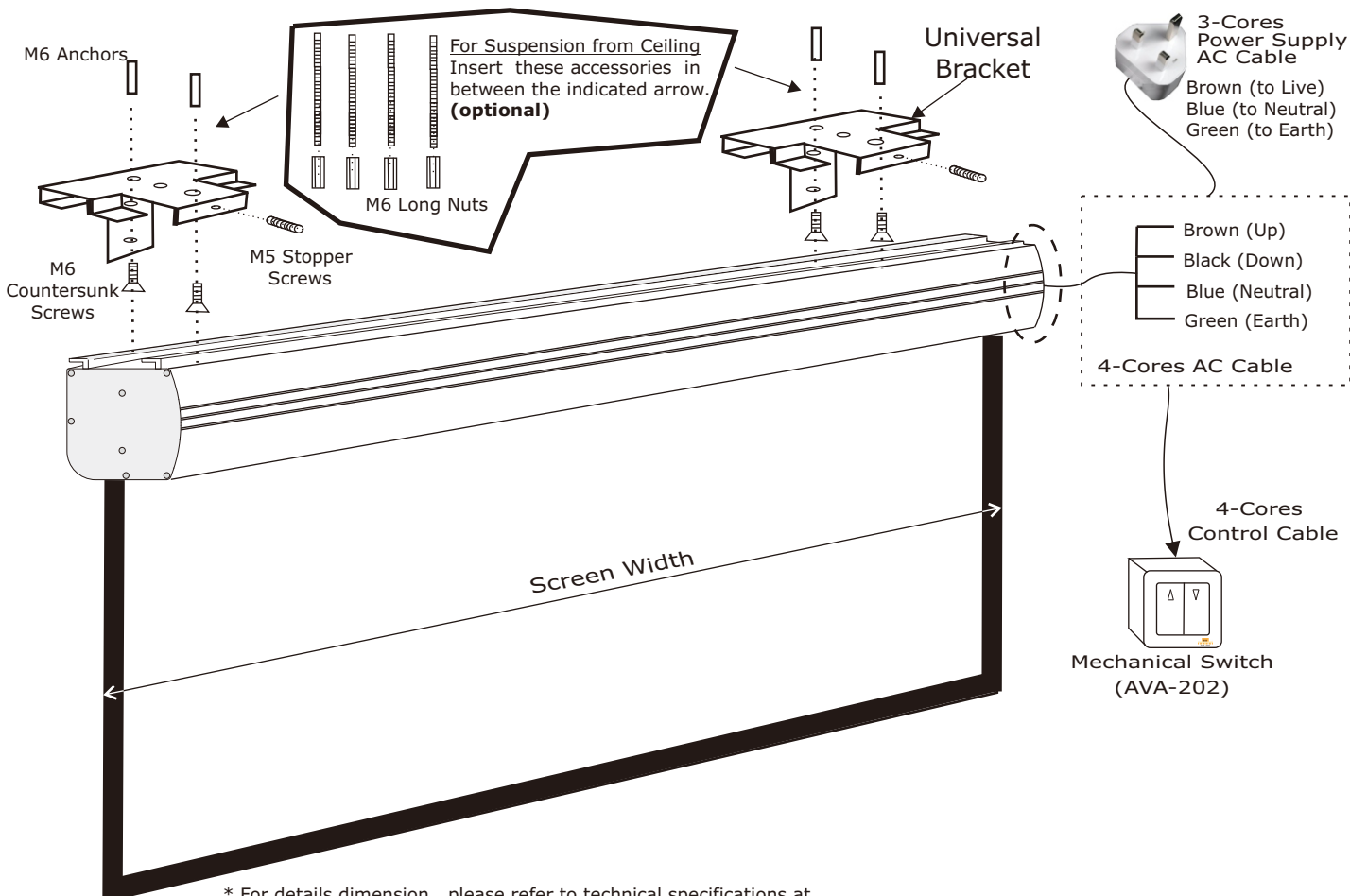
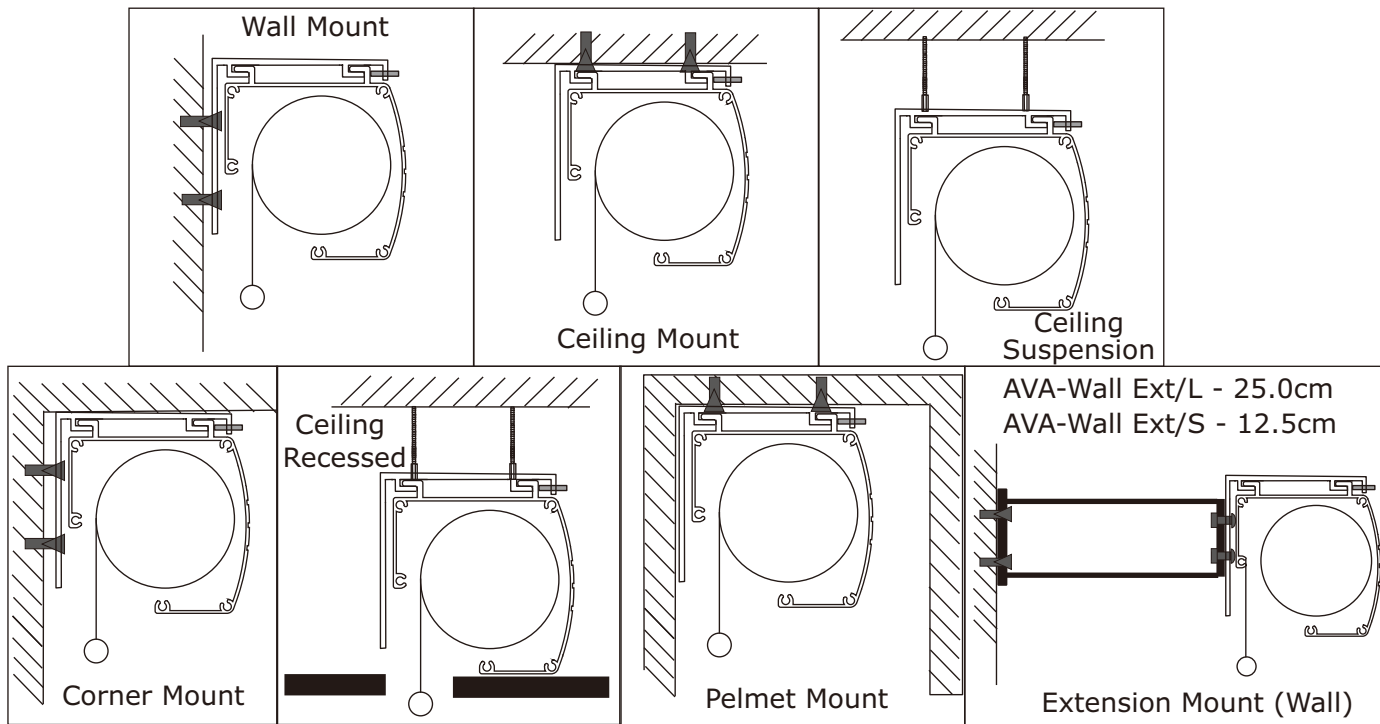

\* For details dimension , please refer to technical specifications at [www.remacotech.com](http://www.remacotech.com)

STEP 1

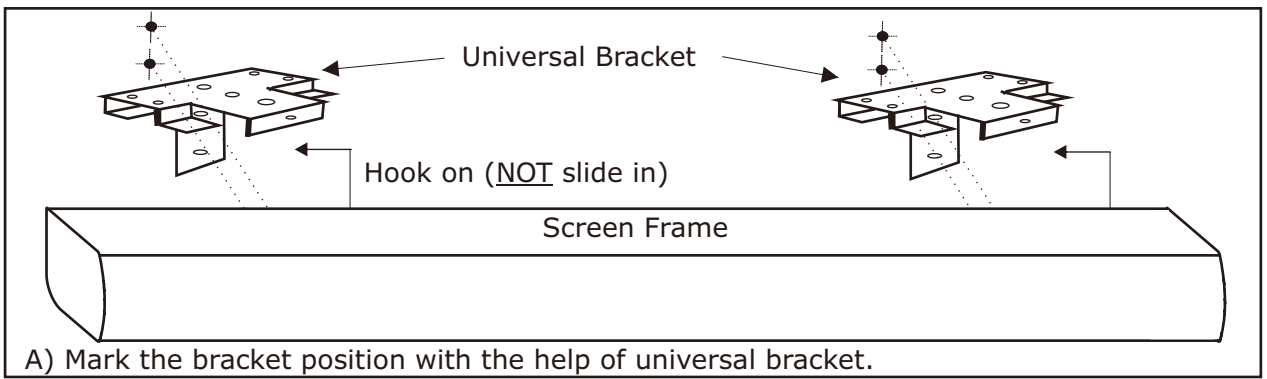

STEP 2

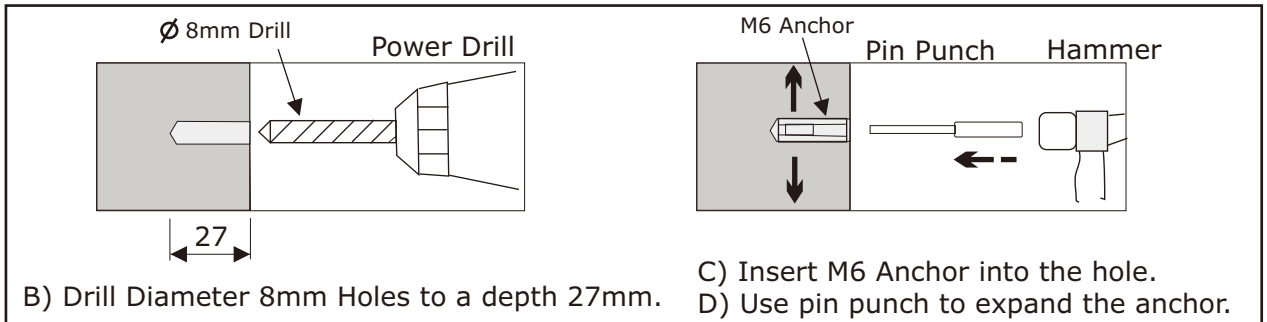

STEP 3

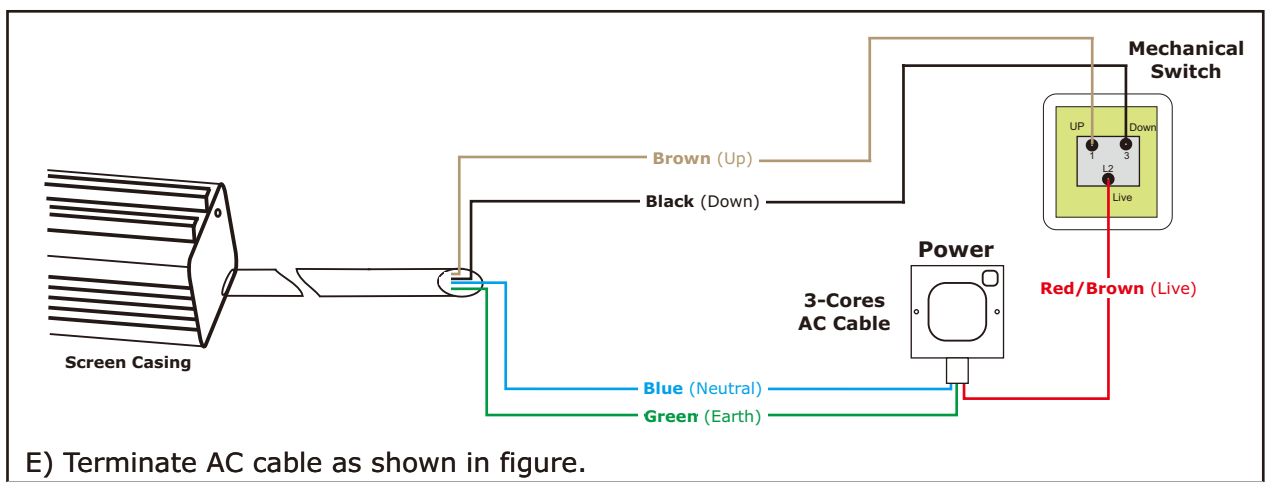

STEP 4

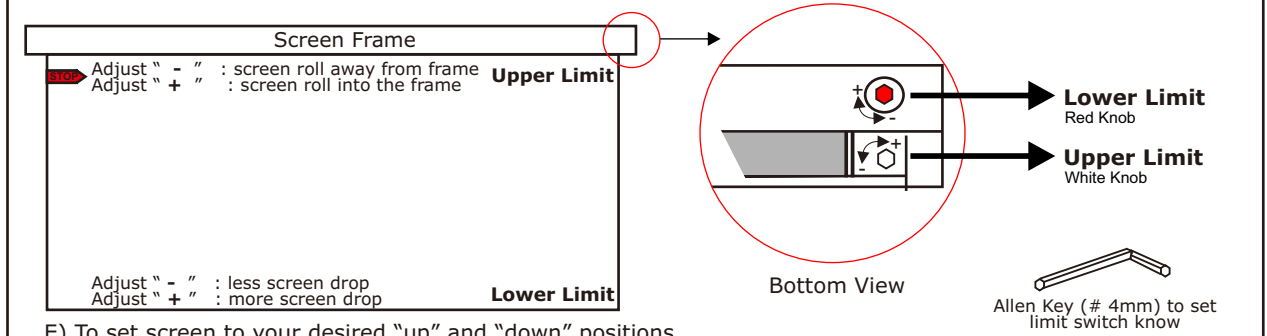

**Important Note**

The upper limit and lower limit of the screen had been preset in factory. Any adjustment to these 2 limit switches may cause damages to the screen fabric. If adjusted, it will cause the following problems:

- a) The screen will roll into the frame and stop by force and not by the Upper Limit switch. This will cause overheating of motor which unable the screen to operate properly.
- b) The depression of the bottom bar onto the fabric will cause horizontal mark on screen surface.
- c) Adjusting the Lower Limit of the screen any lower than beyond the STOP sticker may cause the fabric to drop off

**Disclaimer**

Any adjustment to these 2 limit switches will void the warranty for the screen and Remaco will hold no responsibility for any damages to it. Please consult us if it is necessary to do any adjustment to the limit switch.

**End**